

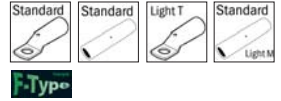

Electro-hydraulic crimping tools

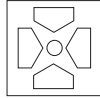

„HD300-6“
Art. 216660



„HD400-6“
Art. 216661



1. Technical data

Area of application:	For the creation of an electrical connection by means of compression
Scope of delivery:	1 crimping tool, 1 gauge, 10 specimens, in plastic case.
Pressing force:	60 kN
Pressing width:	Headstock
Opening:	can be opened
Oil type:	ISO class viscosity 15
Feed rate:	2 speeds: Closing (fast) feed to bring to the conductor and working feed for compression. Switching between the two speeds is carried out automatically.
Safety:	The tool is fitted with a safety valve that has been set at the factory.
Structure:	The working head can be rotated by 360° to make it easier to adapt to the operation to be carried out. The crimping tool does not protect the operator when working on cables that carry power.
Guarantee:	2 year guarantee if used for the purpose it is intended

2. Area of work

- Pressing force in kN: 60
- Working pressure in bar: 700
- Head can be opened
- Pressing width: thorn
- Crimping range cable lugs: 216660: Cu 16-300 / 216661: Cu 25-400
- Crimping range connectors: 216660: Cu 16-120 / 216661: Cu 25-400
- Doppelkolbenpumpe
- Length: 216660: 560 / 216661: 580
- Weight in kg: 216660: 5,0 / 216661: 5,2
- Weight of set in kg: 216660: 6,5 / 216661: 6,7

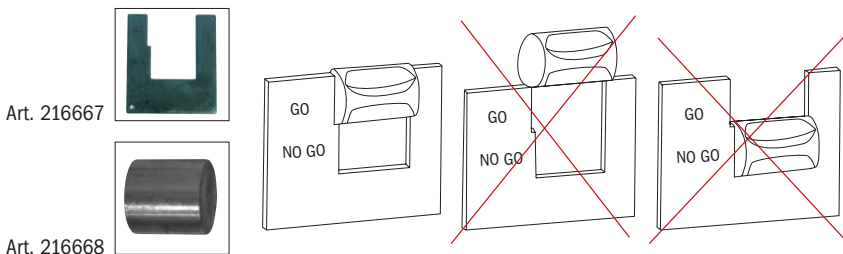

Preparation:

Before starting up the tool, read the operating instructions first.

All current-carrying elements in the area you are working in should be disconnected.

Otherwise the protective procedures for working in the vicinity of components under current must be implemented. (DIN EN 50110)

Do not use the tool if you are tired or under the influence of medication, drugs or alcohol.

Take into account the valid accident prevention and safety regulations and use the tool exclusively for the purpose for which it is intended.

Only electro-technically trained persons over 16 years of age may process connecting materials using the tool.

The operating instructions must always be carried with the tool.

The instructions must have been read and understood by the user.

The operator must ensure that this is the case.

Start:

- The device has a manual return that brings the piston back to the starting point when the maximum pressing force has been achieved.
- The device is equipped with a dual piston pump characterised by fast feed and slow working hub.
- The pressing head can be infinitely rotated by 360° about the longitudinal axis. This enables mounting even in difficult to access locations.
- The pressing head has centring pins which ensure automatic centring of the connection material in the pressing head.



Thorn-pressing

haupa[®]
... convincing solutions

3. Notes regarding correct use

3.1. Operating the device

First, the bolt is removed and the bar opened. The connection material is placed centrally between the 4 pressing spikes.

Then the pump lever is fully closed up again. The actuation of the operating switch triggers the pressing procedure which is characterised by the meeting of the pressing spikes. A pressing procedure is completed when the pressing spikes have been joined and the device switches over to idle.

The return of the piston is carried out manually after the maximum operating excess pressure is reached.

Now a further pressing procedure can be carried out or the bar can be opened and the connection material removed from the pressing head.

Pressing the reset button brings the pressing spikes back to the starting position in the event of faults or an emergency.

The pressing procedure can be interrupted at any time by releasing the pump lever.

Caution!

If the pressing is not centred, this may result in damage to the pressing head!

3.2. Explanation of the areas of application

The pressing tool has pressing spikes that use force to compress copper and aluminium connection materials without the need to change tools.

4. Care and maintenance

4.1. Cleaning

Careful cleaning of the tool, in particular, the moving parts contributes towards a longer useful life. Remember that dust, sand, environmental influences, in particular a high salt index, and dirt in general are extremely damaging to hydraulic tools.

Particular care should be taken when cleaning the pump drive piston and the piston. The tiniest of contaminations may scratch the walls of the cylinder and damage the leak-proof seals.

For the correct cleaning of the piston, we recommend extending the piston and then cleaning it with a high-quality, non-corrosive solution.

4.2. Storage

To prevent damage to the tool as a result of bumps, dust etc. you should if possible store the tools in the carry bag in a warehouse.

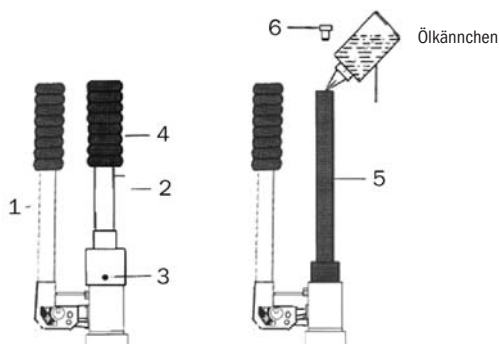

4.3. Checking the oil level

The oil level in the tank should be checked at regular intervals, in particular, when it has been used for a long time and topped up whenever necessary.

- Refilling or filling with oil
- Use only the oil name in section 1 or purchase from the HAUPA service centre (Art. 216254).
- Never use old oil.
- The oil must be clean and may not contain contamination.
- Hold the tool upright so that levers 1 and 4 are pointing upwards.
- Move the piston back as far as it will go, turn the moveable lever (1) by a quarter turn and hold, press the release button until the piston stops on the return journey.
- Remove the stop screw (3) using an Allen key.
- Unscrew the fixed arm (4) and remove.
- Hold the upper section of the tank (5) with one hand and with the other hand

- remove the lid (4). Fill the container to the top and replace the lid. The oil must be distributed throughout the entire container, so that it is impossible for air to enter into the circuit.
- Move the piston forwards with the moveable lever and check for perfect functionality.

Bleeding the hydraulic circuit

- After the lid (6) of the tank has been removed, operate the moveable lever (1) several times to extend the piston.
- Move the piston back again fully, and use a screwdriver or similar object to press the release button to enable the oil to flow back into the container.
- Repeat these steps at least 5 times to fully bleed the entire hydraulic circuit and to remove all air pockets.
- Carry out step 5 from the previous section – "Refilling or filling with oil".
- Apply the handle, tighten the locking screw and check the functionality.
If the tool still not does function correctly despite this maintenance please contact the HAUPA service centre. Only use the oil named in section 1.
- When changing the oil, dispose of the old oil under strict observation of the applicable legal requirements.

4.4. WARNING NOTES!

Caution:

Do not attempt to force the head to turn when the hydraulic circuit is pressurised.

Guarantee:

2 year guarantee when used for the purpose it is intended when the annual maintenance intervals are maintained by an authorised HAUPA service centre. We reserve the right to rework the product.

Disposal:

Individual components must be disposed off separately.
The oil must be drained and disposed of at the designated points.

Caution:

Hydraulic oils represent a risk to the groundwater. Uncontrolled drainage or incorrect disposal carries penalties. (Environmental Liability Law)

The remaining components of the aggregate must be disposed in accordance with the relevant environmental standards.

The disposal should be carried out by authorised specialist companies. The free return to the manufacturer cannot be guaranteed.

Always use original replacement parts. Other parts may seriously damage the tool and will void the guarantee.

If the tool still does not work correctly, send it to the nearest repair service for specialist maintenance and fine tuning, or send an email to: info@haupa.com

WITH EVERY REPLACEMENT PART ORDER, INCLUDE THE FOLLOWING INFORMATION:

- 1) Article number.
- 2) Article description.
- 3) Reference to the operating instructions and/or date.
- 4) Tool type.
- 5) Serial number of the tool.

The guarantee is voided if you use parts that are not original replacement parts from HAUPA.