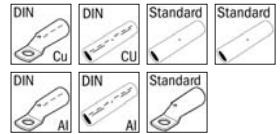

**Crimping tool
„HH-6“****Art. 215800**

1. Technical data Art. 215800

Area of application:	For the creation of an electrical connection by means of compression
Scope of delivery:	1 crimping tool in a plastic case, without dies.
Pressing force:	60 kN
Feed rate:	2 speeds: Closing (fast) feed to bring the pressing dies to the conductor and working feed for compression. Switching between the two speeds is carried out automatically.
Safety:	The tool is fitted with a safety value that has been set at the factory.
Structure:	The working head can be rotated by 180° to make it easier to adapt to the operation to be carried out. The model Art. 215800 does not protect the operator when working on cables that carry power.
Guarantee:	2 year guarantee if used for the purpose it is intended.

2. Area of work

- Pressing force in kN: 60 kN
- Working pressure in bar: 700
- Head can be opened
- Opening/ Hub: 17 mm
- Pressing width: slim
- Crimping range cable lugs: Cu 10-240 • DIN Cu 10-240 • DIN Al 16-185
- Crimping range connectors: Cu 10-240 • DIN Cu 10-240 • DIN Al 16-185
- Dual-piston pump
- Length: 370
- Weight in kg: 3,0
- Weight of set in kg: 4,5

3. Operating instructions

CAUTION! TOOLS MAY NEVER BE USED WITHOUT FIRST INSERTING THE PRESSING DIES.

Ensure that the pressing dies fit precisely to the appropriate area and are seated perfectly in the holders.

OTHERWISE THIS MAY CAUSE SERIOUS DAMAGES OR BREAKAGES AND THE GUARANTEE WILL BE VOIDED.

Introduction:

Before starting up the tool, read the operating instructions first.

All current-carrying elements in the area you are working in should be disconnected.

Otherwise the protective procedures for working in the vicinity of components under current must be implemented. (DIN EN 50110).

Do not use the tool if you are tired or under the influence of medication, drugs or alcohol.

Take into account the valid accident prevention and safety regulations and use the tool exclusi-

vely for the purpose for which it is intended.

The operating instructions must always be carried with the tool.

The instructions must have been read and understood by the user.

The operator must ensure that this is the case.

Performance characteristics:

- 6 tonnes of pressing force for maximum performance
- 180° rotating crimping head. Can thus be mounted even in places that are difficult to access.
- The manual return enables the operator to bring the piston back to the starting point in the event of a faulty pressing.



3.1. Preparation:

- Select the appropriate pressing dies for the connection to be pressed.
- Insert the pressing dies in the tool head. All of the pressing dies that can be used in this model are made up of two parts with identical external measurements, so that the both can be inserted at will into the piston or the head.
- The procedure for inserting pressing dies is identical for mounting to both piston and head.

3.2. Start

- Bring the tool to the working position.
- Select the appropriate pressing dies for the connection to be pressed.
- Insert the pressing dies in the tool head.
- Feed the conductor into the connector.
- Place the connector between the two pressing dies.



3.3. Approach of the pressing dies (closing feed rate)

- Hold the tool securely and press the mobile lever arm to move the piston quickly forwards until the pressing dies meet the connector to be compressed.

3.4. Compression (working feed)

- As soon as the pressing dies start to compress the connectors, the system automatically switches from closing feed to working feed.
- Press until the pressure limiter can be heard or the pressing dies meet and a perceptible discharge of the pump occurs.

3.5. Releasing the pressing dies (return of the piston)

- Activate the release valve lever on the tool so that the piston automatically returns to the basic position or to the desired position.
- This can be carried out during the crimping if you have made an error in the selection of the connector or the die.

4. Diagnosing faults

The following section describes three possible reasons for faulty operation as well as the ways in which they can be eliminated.

1.

With every actuation of the lever the piston experiences a feed motion and then returns back to the starting position.

CAUSE: Air in the hydraulic circuit.

SOLUTION: Let the air out of the hydraulic system; See the explanations in the "Checking the oil level" section.

2.

The feed from the piston is fine, but it is not possible to fully complete the pressing.

a) CAUSE: Lack of oil.

SOLUTION: Fill the tank; See the explanations in the "Checking the oil level" section.

b) CAUSE: As a result of contamination in the closing stamp, oil exits the pressure limiting valve.

SOLUTION: Hold down the release level and operate the drive lever forcefully approximately 10 times. This should wash away the contaminations in the safety valve so that the pump works properly again.

If the tool still does not work, send the tool to the HAUPA service centre for fine tuning by our specialist staff. Do not send accessories as these are not necessary.

3.

Tool oil loss.

CAUSE: Sealing rings are defective or deformed

SOLUTION: Please send the tool to the HAUPA service centre. Do not open!

5. Care and maintenance

5.1. Cleaning

Careful cleaning of the tool, in particular, the moving parts contributes towards a longer useful life. Remember that dust, sand, environmental influences, in particular a high salt index, and dirt in general are extremely damaging to hydraulic tools.

Particular care should be taken when cleaning the pump drive piston and the piston. The tiniest of contaminations may scratch the walls of the cylinder and damage the leak-proof seals.

For the correct cleaning of the piston, we recommend extending the piston and then cleaning it with a high-quality, non-corrosive solution.

5.2. Storage

To prevent damage to the tool as a result of bumps, dust etc. you should if possible store the tools in the carry bag in a warehouse.

5.3. Checking the oil level

The oil level in the tank should be checked at regular intervals, in particular, when it has been used for a long time and topped up whenever necessary.

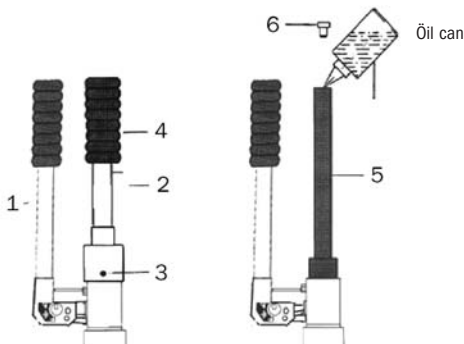

- Refilling or filling with oil
- Use only the oil name in section 1 or purchase from the HAUPA service centre (Art. 216254).
- Never use old oil.
- The oil must be clean and may not contain contamination.
- Hold the tool upright so that levers 1 and 4 are pointing upwards.
- Move the piston back as far as it will go, turn the moveable lever (1) by a quarter turn and hold, press the release button until the piston stops on the return journey.
- Remove the stop screw (3) using an Allen key.
- Unscrew the fixed arm (4) and remove.
- Hold the upper section of the tank (5) with one hand and with the other hand remove the lid (4). Fill the container to the top and replace the lid. The oil must be distributed throughout the entire container, so that it is impossible for air to enter into the circuit.
- Move the piston forwards with the moveable lever and check for perfect functionality.

Bleeding the hydraulic circuit

- After the lid (6) of the tank has been removed, operate the moveable lever (1) several times to extend the piston.
- Move the piston back again fully, and use a screwdriver or similar object to press the release button to enable the oil to flow back into the container.
- Repeat these steps at least 5 times to fully bleed the entire hydraulic circuit and to remove all air pockets.
- Carry out step 5 from the previous section – "Refilling or filling with oil".
- Apply the handle, tighten the locking screw and check the functionality.
If the tool still not does function correctly despite this maintenance please contact the HAUPA service centre. Only use the oil named in section 1.
- When changing the oil, dispose of the old oil under strict observation of the applicable legal requirements.

5.4. WARNING NOTES!**Caution:**

Do not attempt to force the head to turn when the hydraulic circuit is pressurised.

Guarantee:

2 year guarantee when used for the purpose it is intended when the annual maintenance intervals are maintained by an authorised HAUPA service centre. We reserve the right to rework the product.

Disposal:

Individual components must be disposed off separately.
The oil must be drained and disposed of at the designated points.

Caution:

Hydraulic oils represent a risk to the groundwater. Uncontrolled drainage or incorrect disposal carries penalties. (Environmental Liability Law)

The remaining components of the aggregate must be disposed in accordance with the relevant environmental standards.

The disposal should be carried out by authorised specialist companies. The free return to the manufacturer cannot be guaranteed.

WITH EVERY REPLACEMENT PART ORDER, INCLUDE THE FOLLOWING INFORMATION:

- 1) Article number.
- 2) Article description.
- 3) Reference to the operating instructions and/or date.
- 4) Tool type.
- 5) Serial number of the tool.

The guarantee is voided if you use parts that are not original replacement parts from HAUPA.

haupa[®]

... convincing solutions